

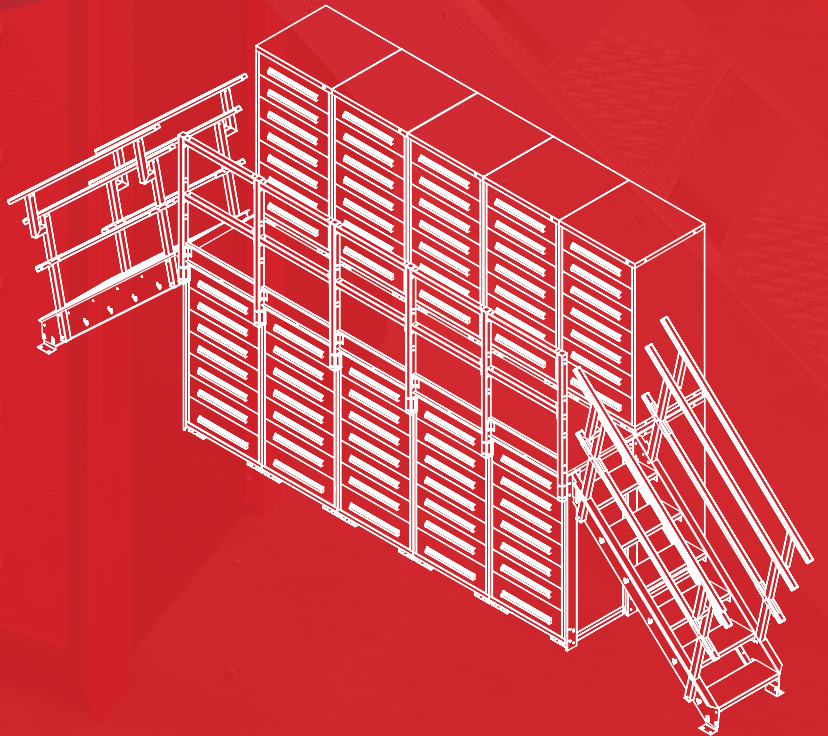

MODULAR CABINET MEZZANINE

— Powered by Equipto

Double storage capacity within the existing floor space, with customizable, easily accessible, and safe storage solutions without the cost of physical expansion.



EQUIPTO[®]

ONE DECISION • INFINITE SOLUTIONS

800.323.0801

sales@equipto.com

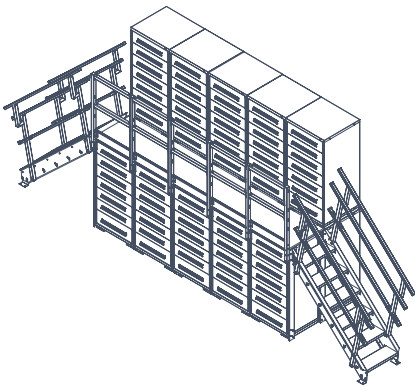

MODULAR STORAGE: MAXIMIZE SPACE EFFICIENTLY

Our new Modular Cabinet Mezzanine (MCM) brings together our best features: sturdy drawer cabinets, safe stairs, railings, and floors, offering an efficient storage solution. It's ideal for businesses wanting to use their current space better. As always, it meets our high standards for durability and safety, providing the quality our clients trust.



FRONT

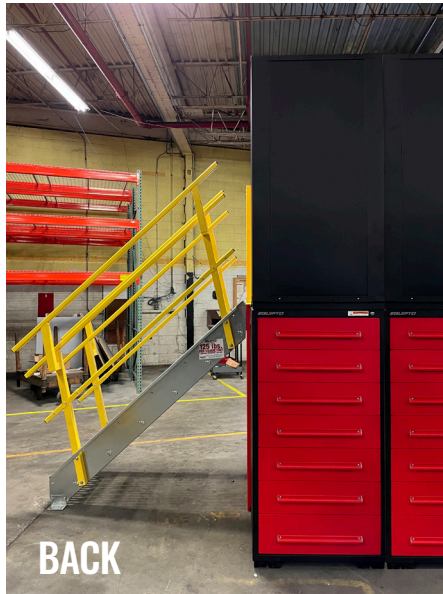

BACK

Double Storage Capacity without Expanding Your Footprint

The MCM system sets itself apart by not only doubling storage capacity within the same footprint through a configurable mezzanine level with drawers and/or shelving but also by including storage cabinets on the back side. This smart design makes better use of space compared to usual storage or adding more room.

BUILT WITH PROVEN COMPONENTS



MODULAR
DRAWER CABINETS



OSHA
STAIRWAYS



SAFETY RAILINGS
AND FLOOR

EXPAND STORAGE UPWARDS, NOT OUTWARDS

MODULAR DRAWER CABINET

One Cabinet Housing & Multiple Drawer Configurations

Standard cabinet height (59"), width (30"), and depth (27.75"). Top drawer is restricted to the 7.5" height, and all other drawers can vary in height from the 16 different options. Using EQUIPTO's unique point system ensures that the cabinets are fully optimized.

Drawer Divider Options

Maximize storage within the drawer organization with different divider kit configurations, design your own configuration with our dividers and partitions or choose no dividers for an open inside of a drawer.

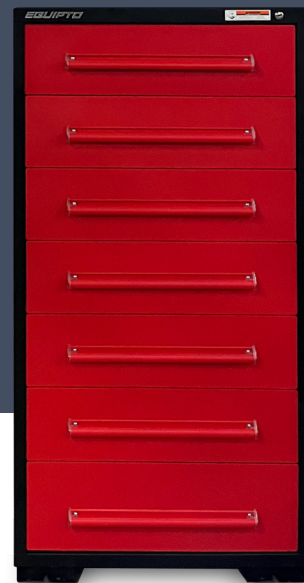

Flexible Design:
Upper Cabinets Feature
Cabinets with Drawers and
Optional Shelves

OUR PROMISE

All Steel Drawer Components

Drawer structure is constructed from all steel components for increased durability and strength.



RAILING & FLOOR

OSHA compliant contoured handrail and post design for comfort, protection, and safety precautions. ResinDek™ Platform, a skid resistant decking.

OSHA STAIRS

- Contoured handrails
- Innovative post design
- Non-skid treads
- Exceed OSHA standards
- Hot dipped galvanized steel construction
- Prefabricated
- Easy to assemble
- Cost-effective



100% AMERICAN MADE



EQUIPTO

Complementary Products

In addition to our modular drawer cabinets, we're proud of our portfolio of space utilization and material handling solutions, including:

PLATFORMS & MEZZANINES

Increase your existing storage space by building up, not out

SHELVING

Including our patented V-Grip™ storage system that combines drawers and shelving for the ultimate in storage adaptation and flexibility

MOBILE AISLE STORAGE SYSTEMS

Created when our shelves, drawers, and racks are mounted on a carriage or rail system — eliminating static storage areas and doubling storage capacity

WORKBENCHES AND WORKCENTERS

Built to provide years of useful, rugged, and efficient space utilization — available in wall-mounted or freestanding units, with or without drawers, and with a variety of accessories

100 YEARS, 100% AMERICAN MADE

We've been creating high-quality, made-in-America products for over a century, and we're not slowing down anytime soon. Our shelving, storage, mezzanine, and conveyor crossover solutions have been installed by some of the largest and most well-known companies in the world, including Harley Davidson, Caterpillar, Boeing, and more.

sales@equipto.com | equipto.com

DESIGNED FROM THE INSIDE OUT

Pre-Configured or Custom

Designed to make purchasing as easy as 1, 2, 3 with pre-configured options or custom-design to meet your unique needs

Drawer Variety

Select drawer sizes and/or a combination of sizes (using our point system to fill the cabinet). Optional dividers or partitions with different configurations in each drawer. Or rubber mat drawer inserts

Only the Best Materials

From one-piece welded construction of 12 ga. steel to all metal wheels and bearings for drawers to a variety of tops

Design Options

Choose all one color or multiple colors for each main cabinet component. Choose a cabinet top for a work surface made out of: Solid hardwood laminate, stainless steel, wood or laminated surface

800.323.0801

EQUIPTO

ONE DECISION • INFINITE SOLUTIONS

225 Main Street | Tatamy, PA 18085